

SUNFIX

engineered solar support

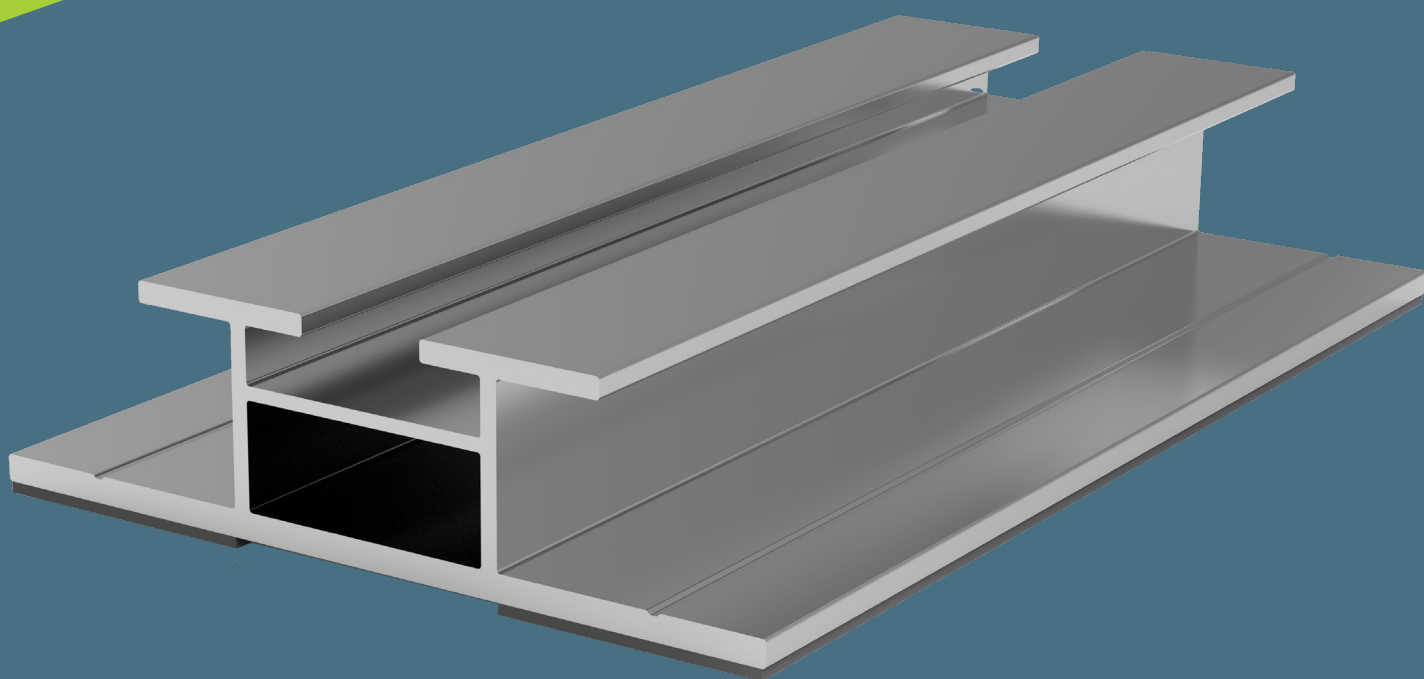

Installation Manual

Corrugated Roofs



Contact Us

Content

	PAGE
Responsibility & Structural Requirements	1
General Guidelines & Safety	1
Technical Guidelines	2
Components Required	3
Tools Required	4
Installation Guide	5
Rail Joiner Guide	18
Post Installation	20

Responsibility & Structural Requirements

Before installing a SunFix Roof Mounted Solar Support System, the structural stability and integrity of the roof must be verified for all dead loads, imposed loads, and wind loads. It is the installers responsibility to ensure the roof has been inspected and deemed suitable by a suitably qualified Professional Structural Engineer prior to installation.

A Professional Structural Engineer must be engaged to design any roof mounted solar support system. When using SunFix components, the engineer must refer to the SunFix Engineers Aid for guidance.

A General Arrangement (GA) drawing, showing the roof layout and the associated solar array, is required for the successful planning and completion of roof mounted solar installations.

SunFix offers engineering consulting and drawing services through our in-house Professional Engineers. Contact us for more information.

General Guidelines & Safety

- Ensure that the substructure of the roof you are installing on is suitable for the additional loads which will be transferred to it via the installation of the SunFix Roof Mounted Solar Support System.
- Ensure that any specific guidelines provided by the roof manufacturer for the roof type on which the SunFix Roof Mounted Solar Support System will be installed are strictly adhered to.
- Always comply with all applicable health and safety procedures, industry standards, and legal requirements throughout the installation process.
- Before starting the installation, review the installation manual carefully to familiarise yourself with the components and installation methodology.
- Roofs have safe zones where solar modules can be installed. However, there are also high-risk zones on all roofs, and the mounting of solar modules therein requires additional consideration by the design engineer. Refer to the SunFix Engineers Aid for more information.
- Do not modify or substitute any SunFix components in any way.
- Always handle and transport SunFix components with reasonable care and ensure they do not come into contact with heavy or sharp objects. It is the installers responsibility to ensure that the components installed are not damaged in any way.
- Do not use the SunFix Roof Mounted Solar Support System for any other purpose other than supporting solar modules. For other uses, such as walkway supports, contact SunFix for further information.
- When setting out any solar module array, you must use a builders line to ensure the system is aligned and installed as per the GA drawing.
- Keep the work area clean and tidy at all times. Remove all swarf, shavings, off-cuts and dirt from the roof surface to prevent corrosion, damage or safety hazards.

Technical Guidelines

Rail Orientation

Depending on the solar module array and roof layout, the SunFix Rail can be installed either perpendicular (across) or parallel (up/down) to the roof slope:

- **Perpendicular to the roof slope (across):**
The rail can be orientated with the side mounting slot facing either upslope or downslope. It is recommended to install the rail with the side mounting slot facing downslope to limit water ingress and ponding within the side mounting slot.
- **Parallel to the roof slope (up/down):**
The rail can be oriented with the side mounting slot facing in either direction.

Roof Slope

The SunFix Rail and other roof mounting components can be installed on roofs with pitches between 3° and 45°. For roof slopes outside of this range, contact SunFix for more information.

Rail Joining

The SunFix Rail Joiner features an integrated expansion joint, enabling an unlimited number of rails to be joined to form a continuous rail run. For each continuous run:

- Joiners must not be installed in adjacent rail spans and should be separated by at least one full span.
- Joiners must not be installed in end spans.

CORRECT PLACEMENT OF RAIL JOINERS

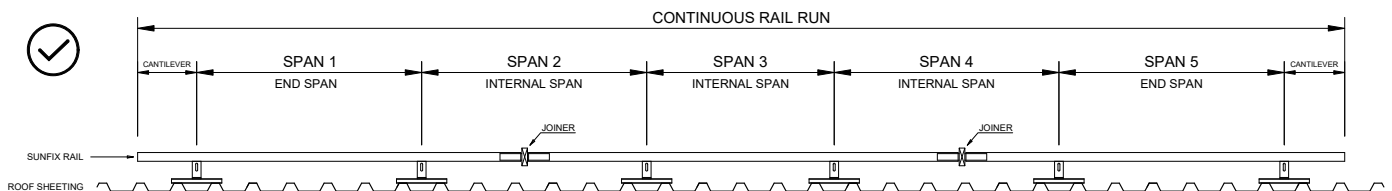

INCORRECT PLACEMENT OF RAIL JOINERS

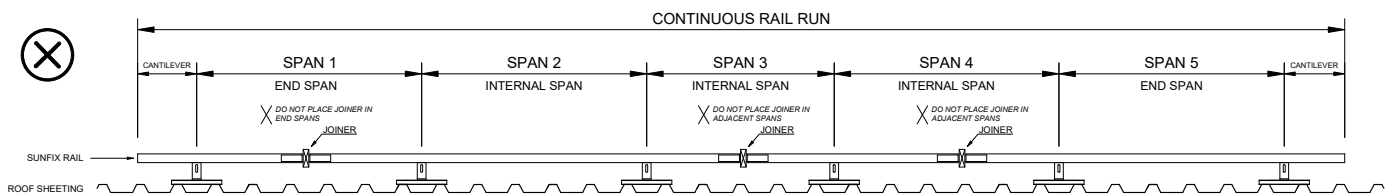

Rail Cantilever

At both ends of each SunFix Rail run:

- The maximum rail cantilever beyond the end support must be less than 300mm.
- A minimum rail cantilever of 50mm beyond the end support must be maintained.

MAXIMUM CANTILEVER

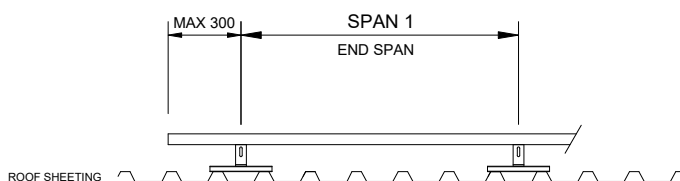

MINIMUM CANTILEVER

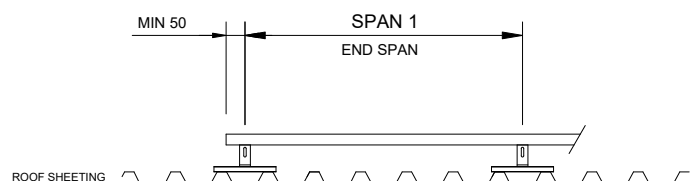

Components Required

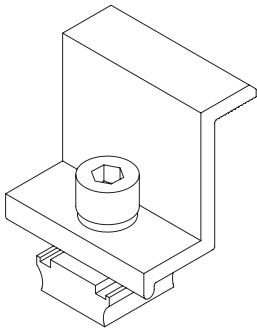

End Clamp
ENDC-00MM-01

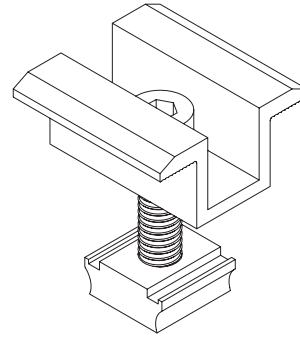

Mid Clamp
MIDC-00MM-01

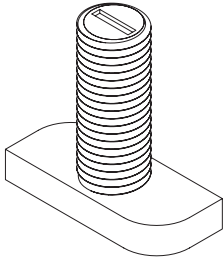

Hammerhead T-Bolt
M8 x 20mm
HHTB-M820-01

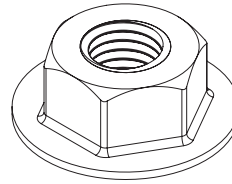

Flanged Nut M8
FLNT-00M8-01

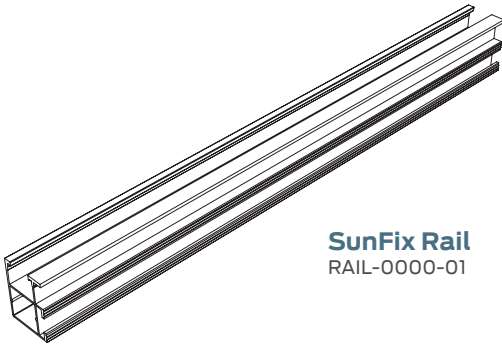

SunFix Rail
RAIL-0000-01

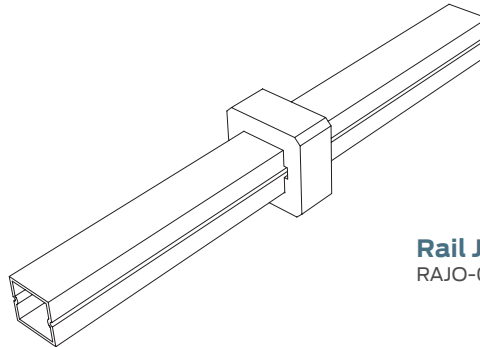

Rail Joiner
RAJO-0260-01

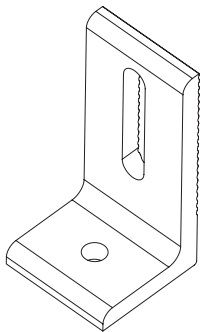

L-Bracket M8
LBRA-00M8-01

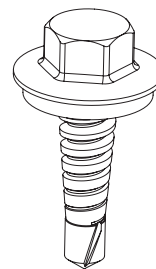

Stitching Screw
12 x 22mm
STSC-1222-01

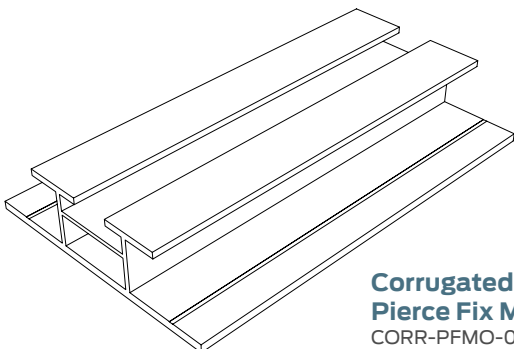

Corrugated
Pierce Fix Mount
CORR-PFMO-01

Tools Required

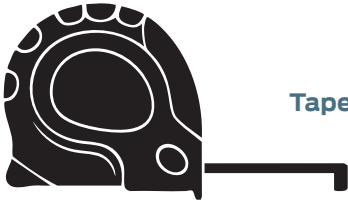

Tape Measure

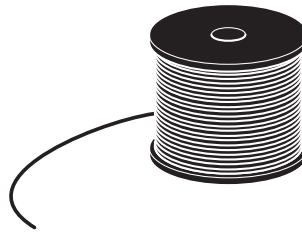

Builders Line



Socket 13mm



Allen Key Driver
Bit 6mm



Torque Wrench



Drill

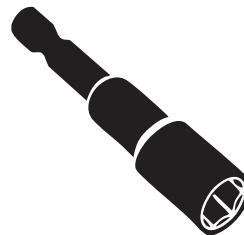

Nut Setter 8mm

Installation Guide

Step 1 of 26

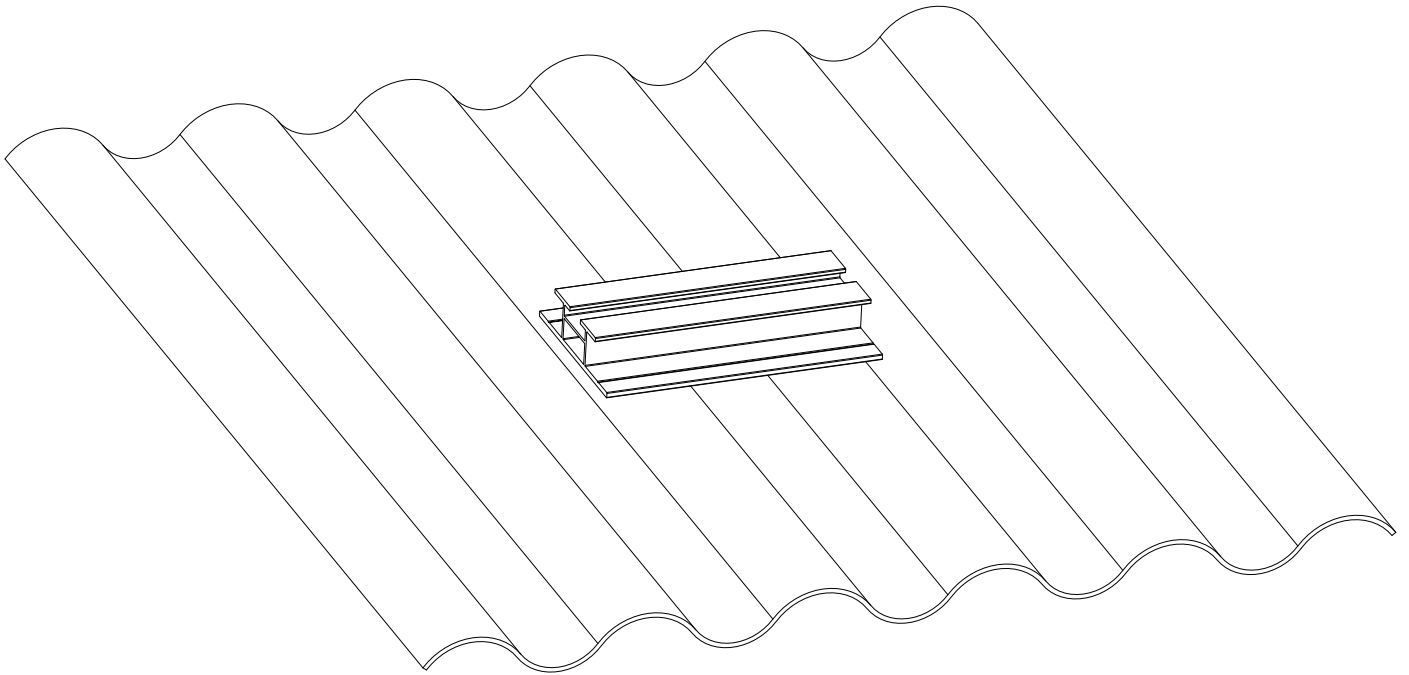

Step 2 of 26

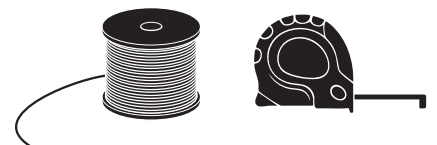
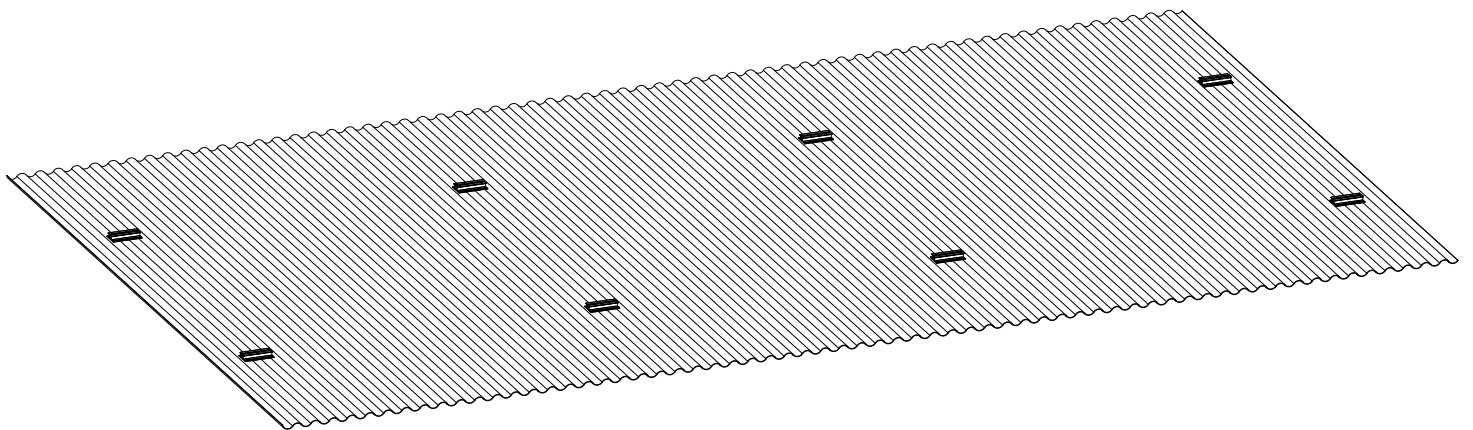

Installation Guide (continued)

Step 3 of 26

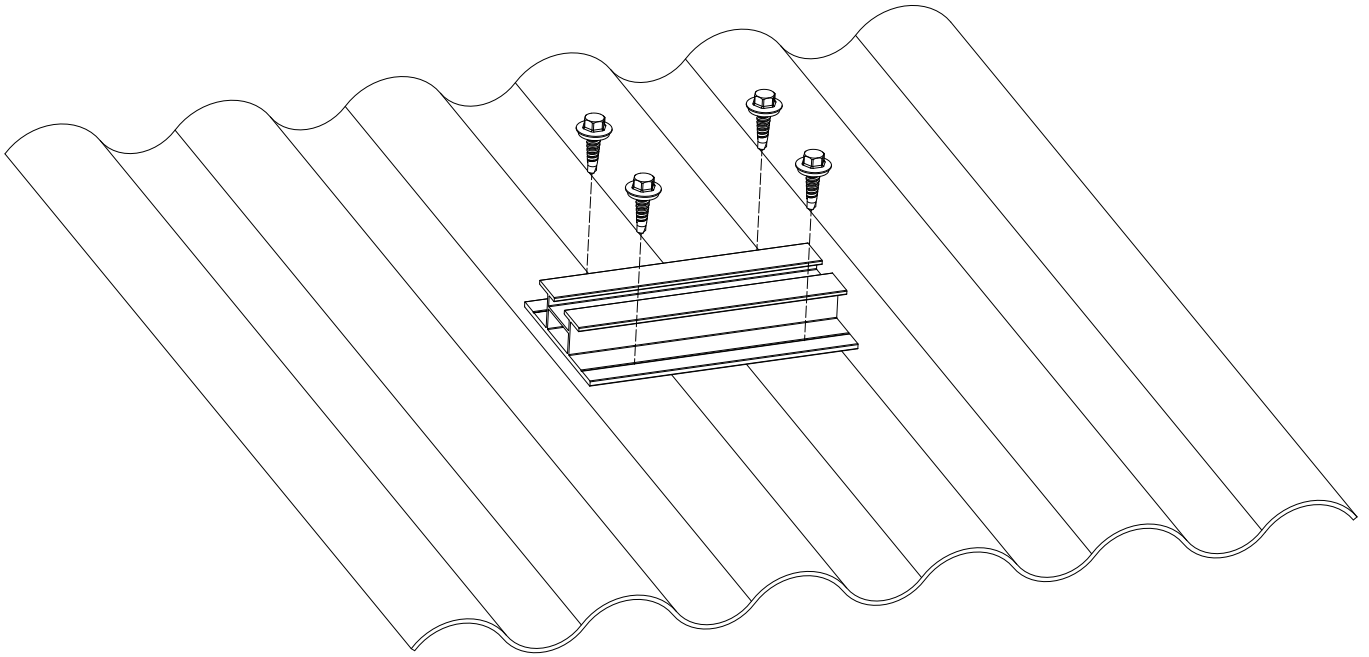

Do not under-tighten or over-tighten the stitching screws.



Step 4 of 26

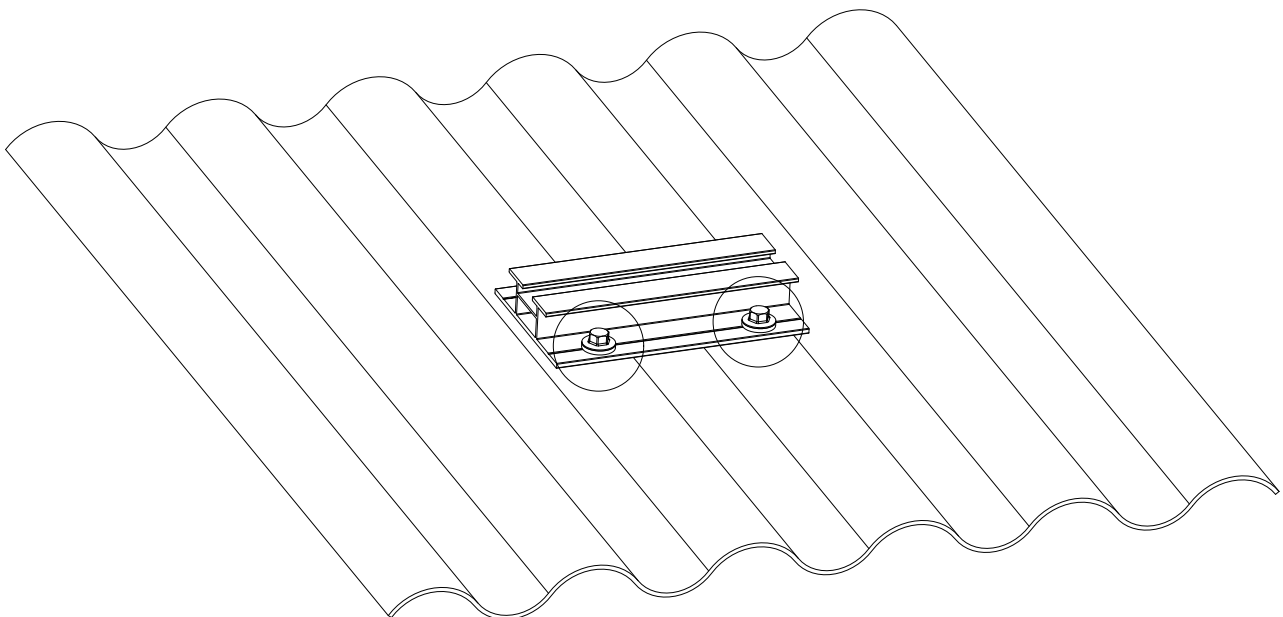
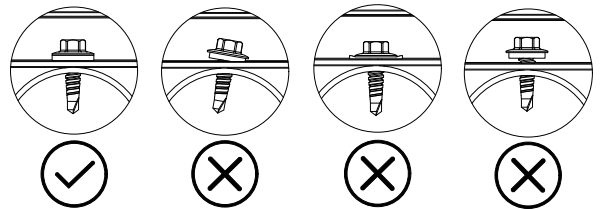

Installation Guide (continued)

Step 5 of 26

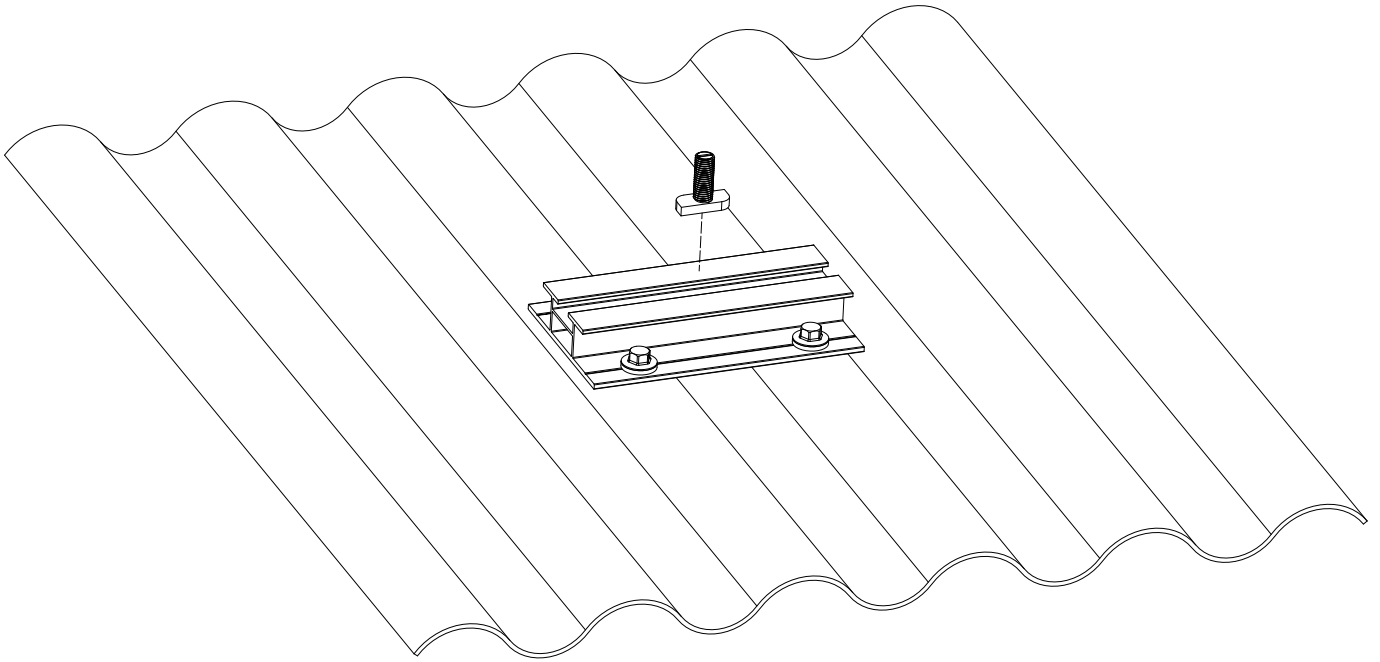

Step 6 of 26

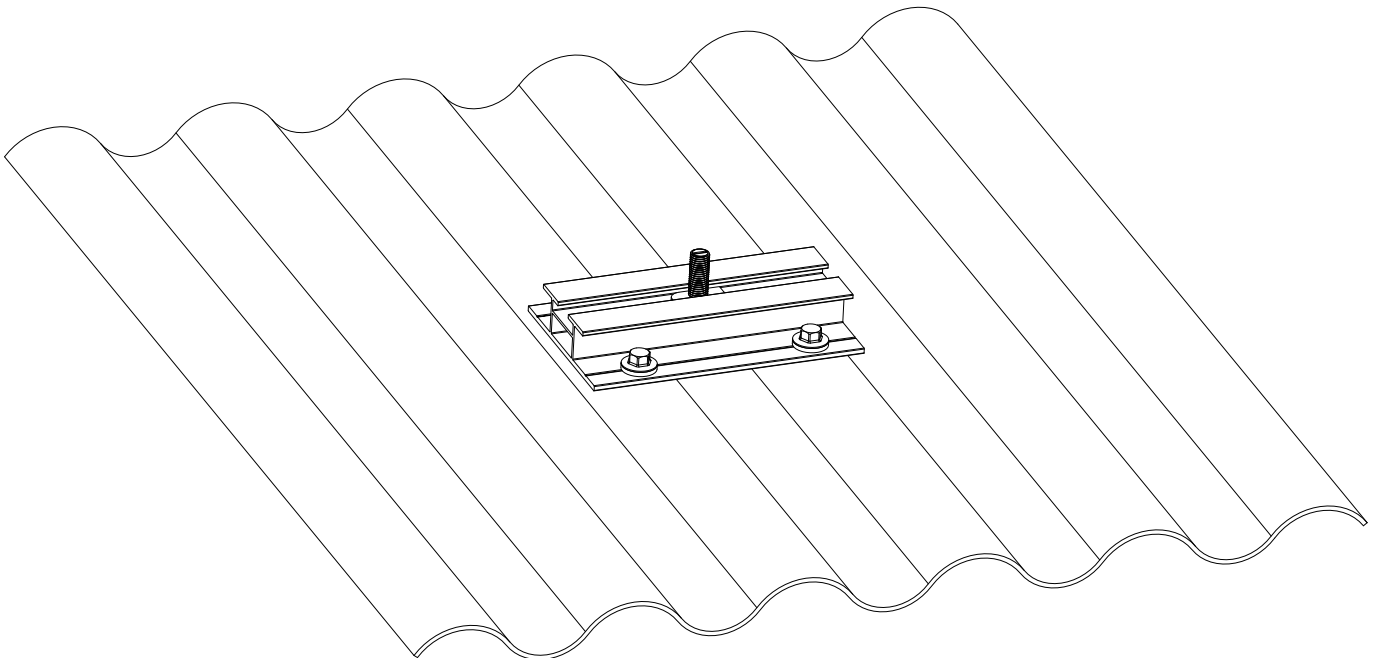

Installation Guide (continued)

Step 7 of 26

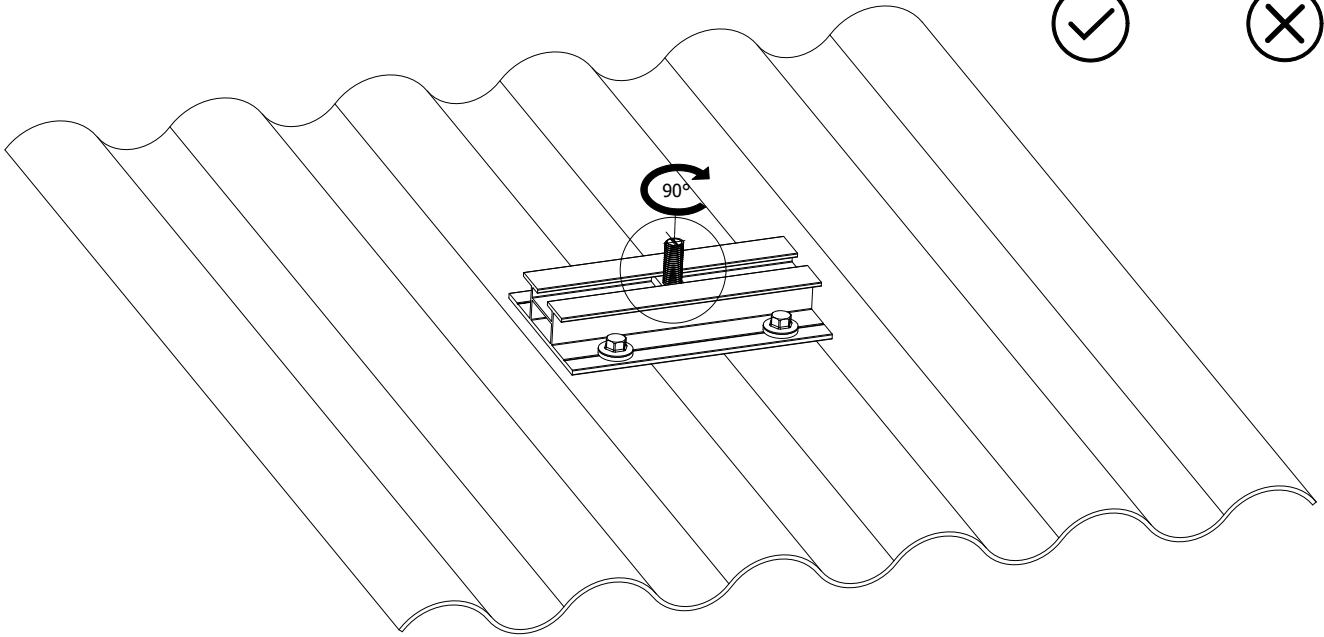
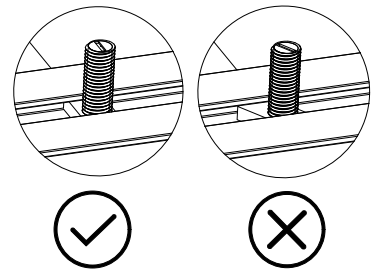

Step 8 of 26

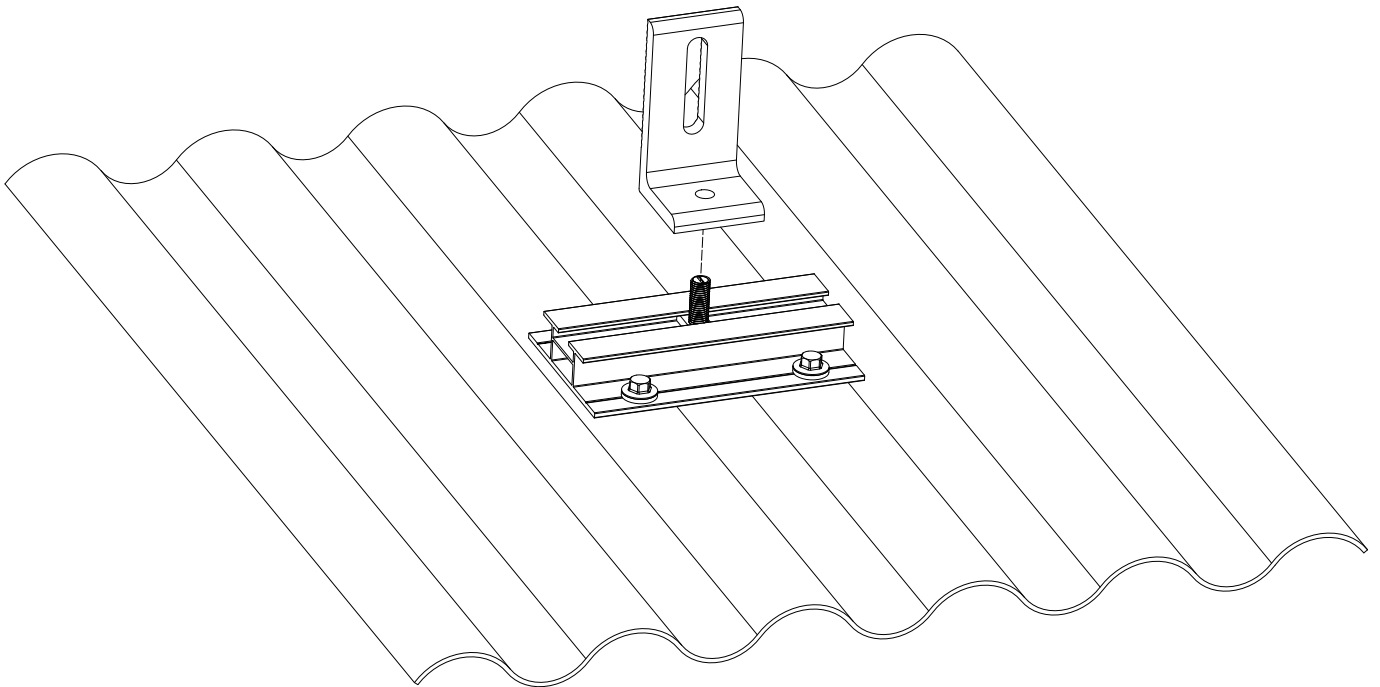

Installation Guide (continued)

Step 9 of 26

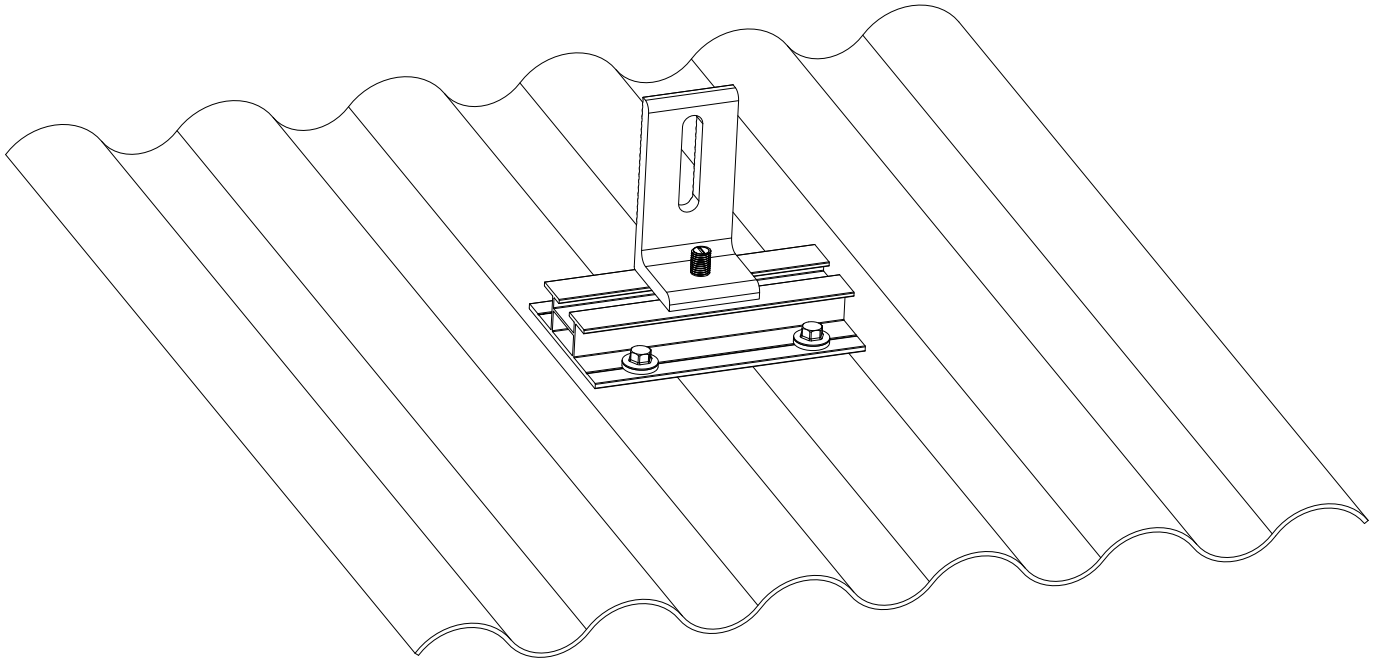

Step 10 of 26

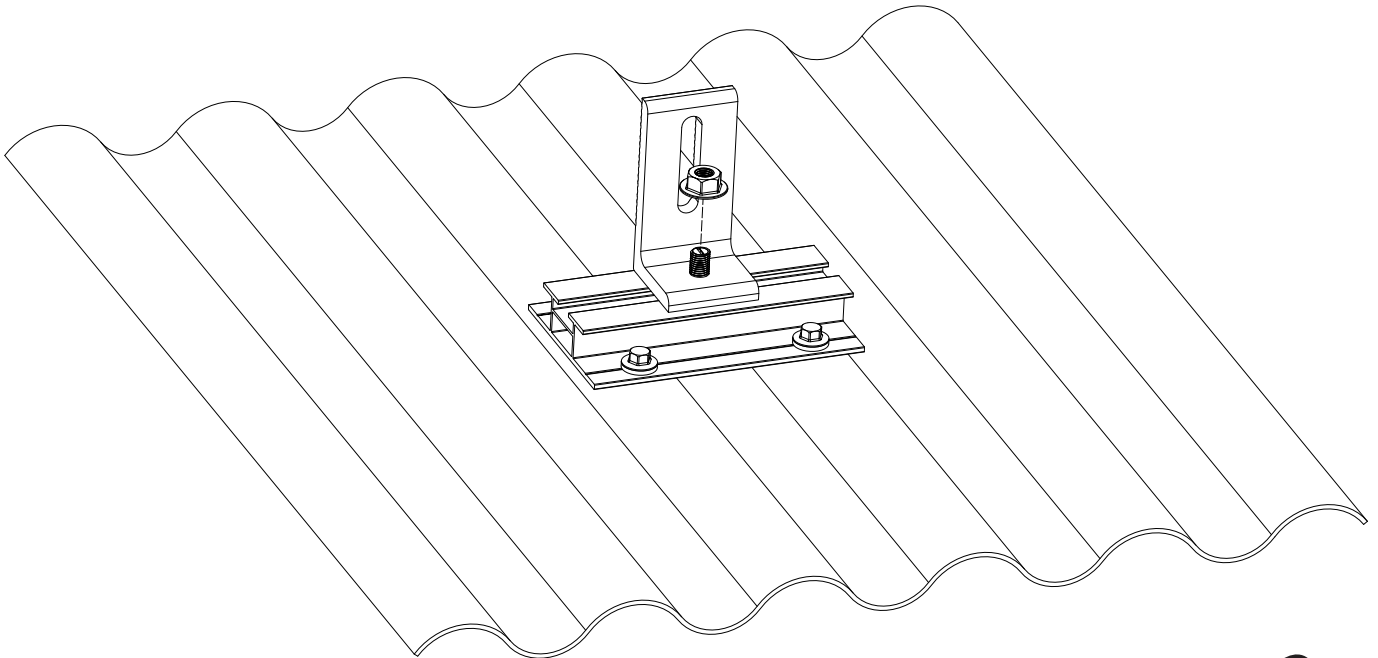

15 Nm



Installation Guide (continued)

Step 11 of 26

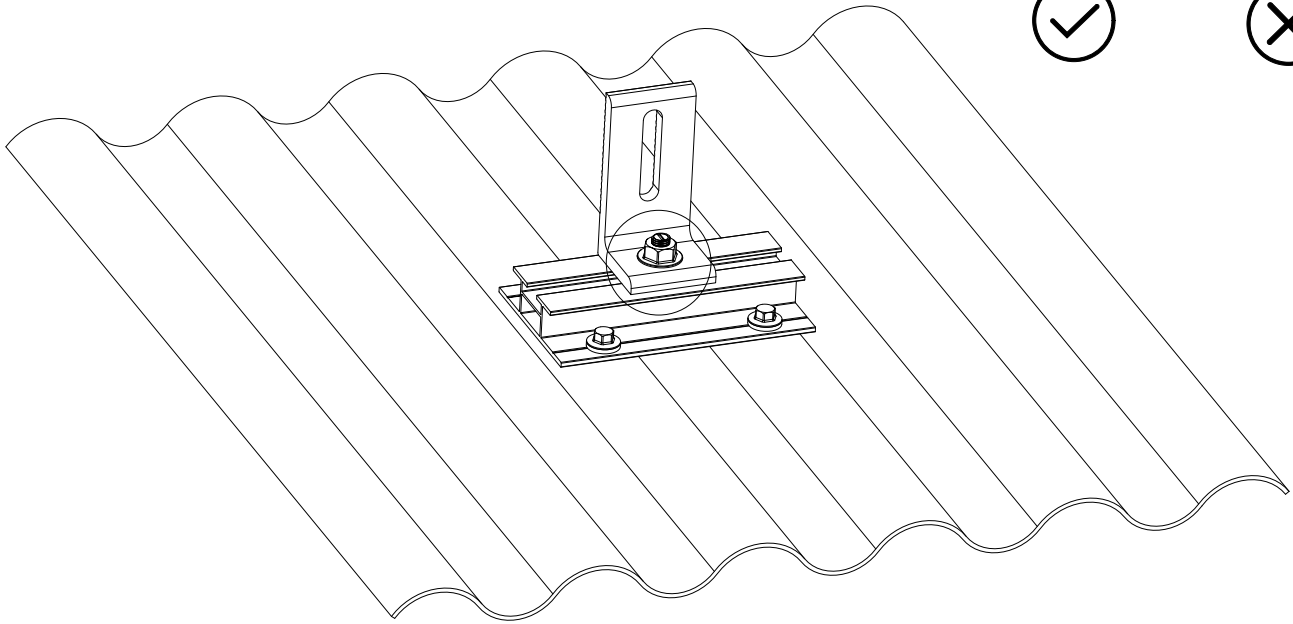
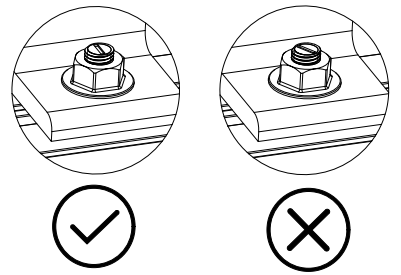

Step 12 of 26

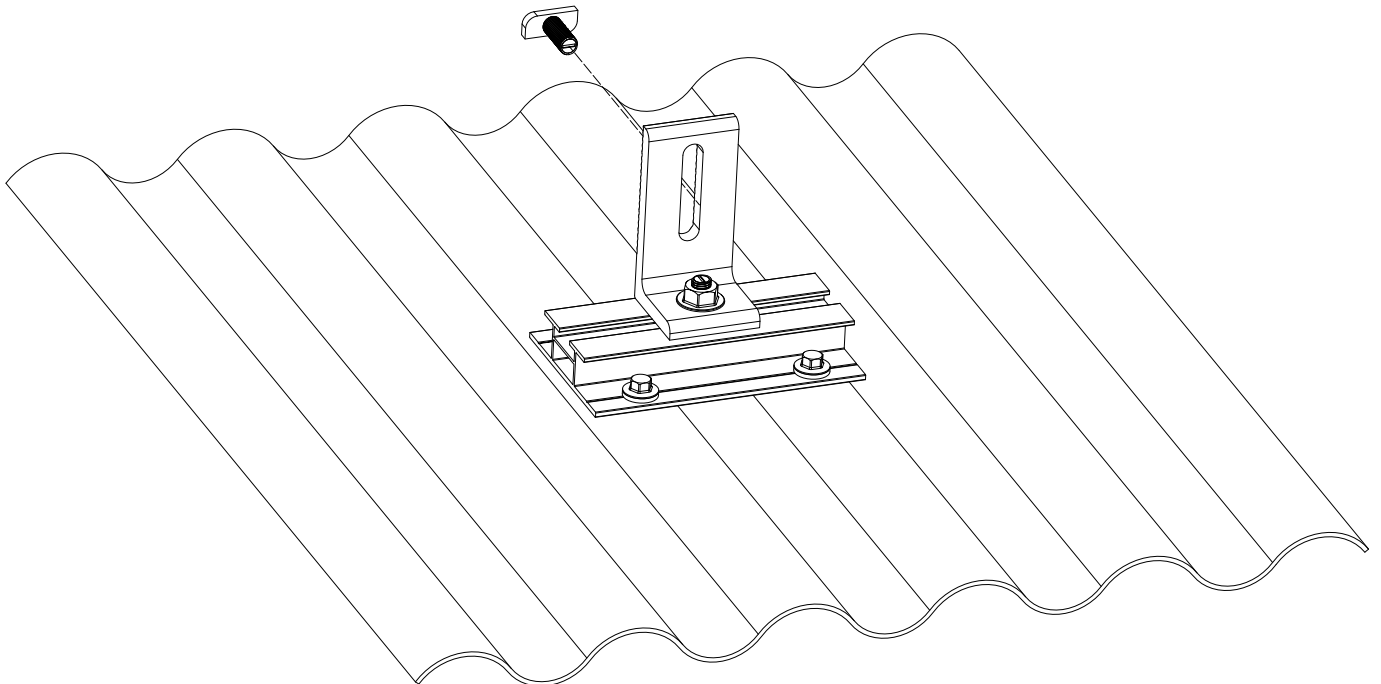

Installation Guide (continued)

Step 13 of 26

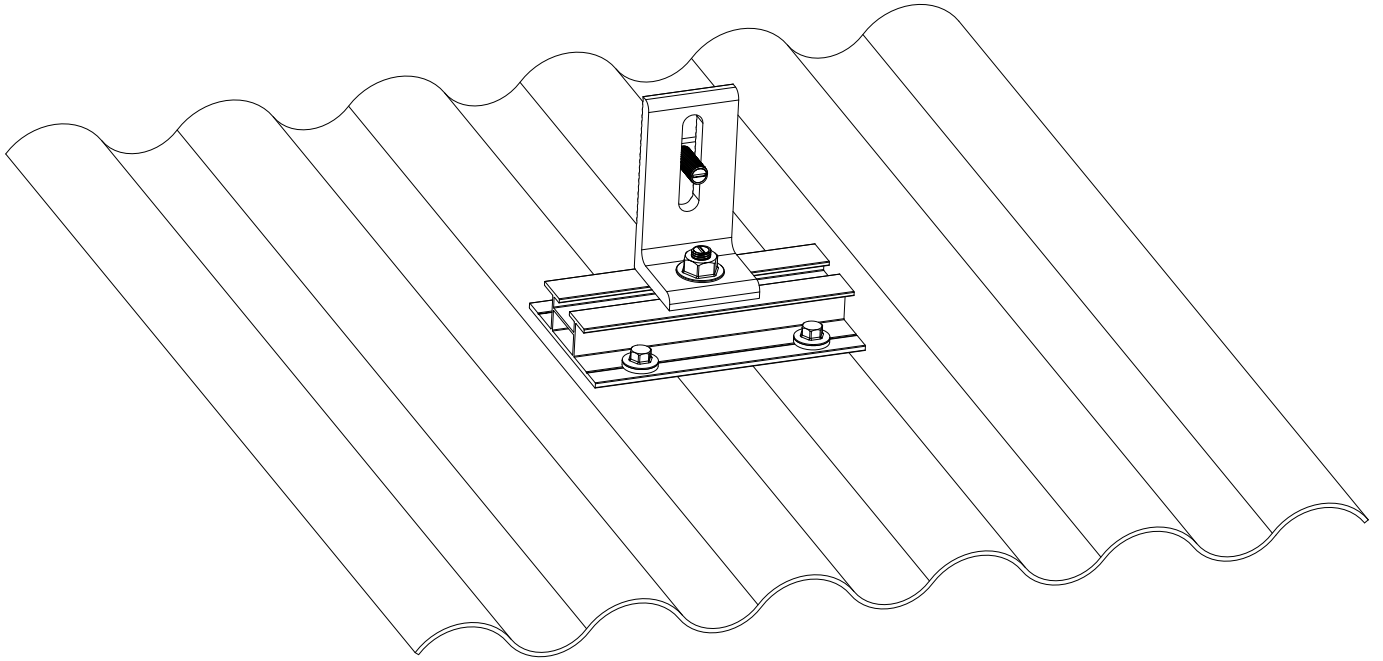

Step 14 of 26

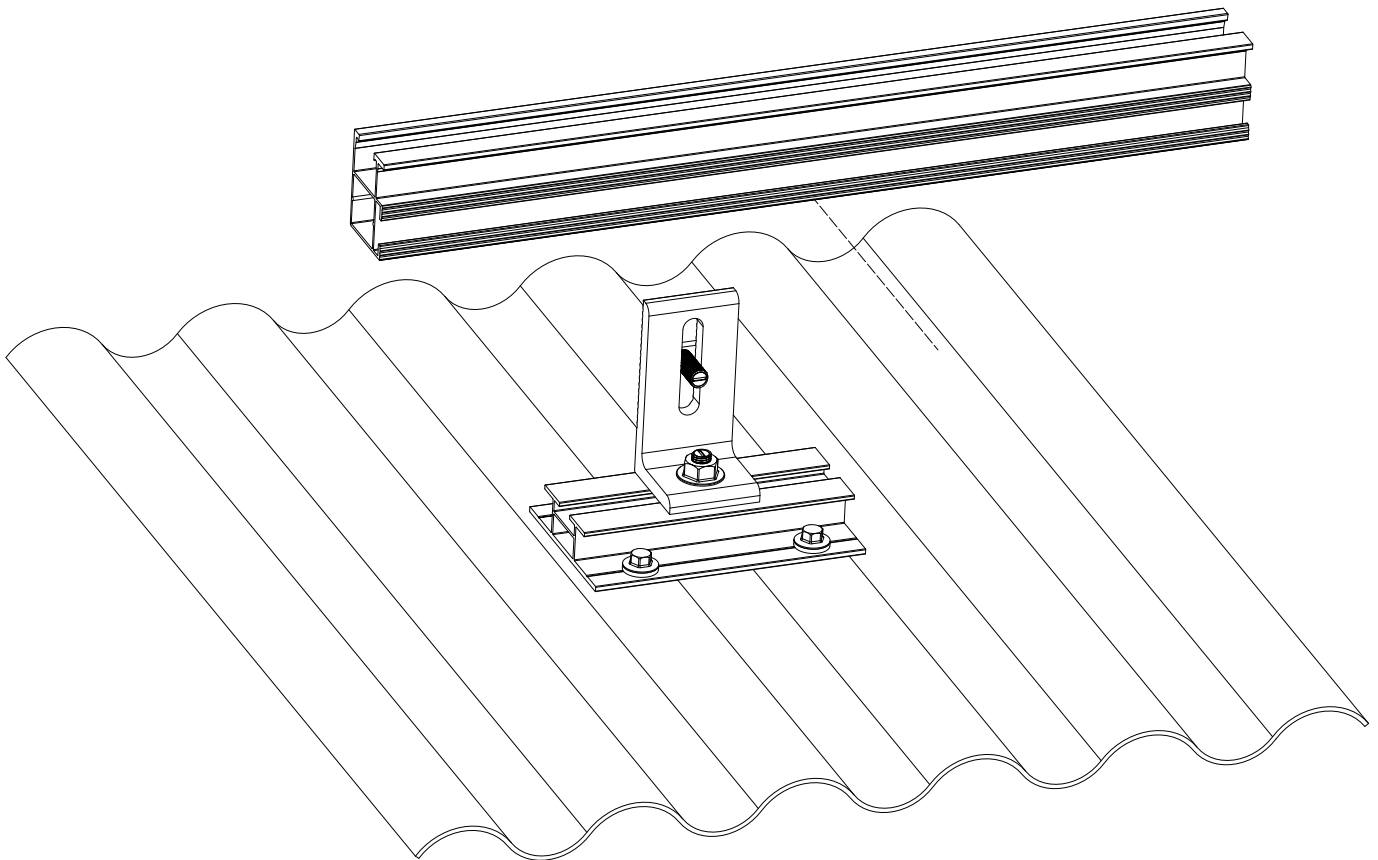

Installation Guide (continued)

Step 15 of 26

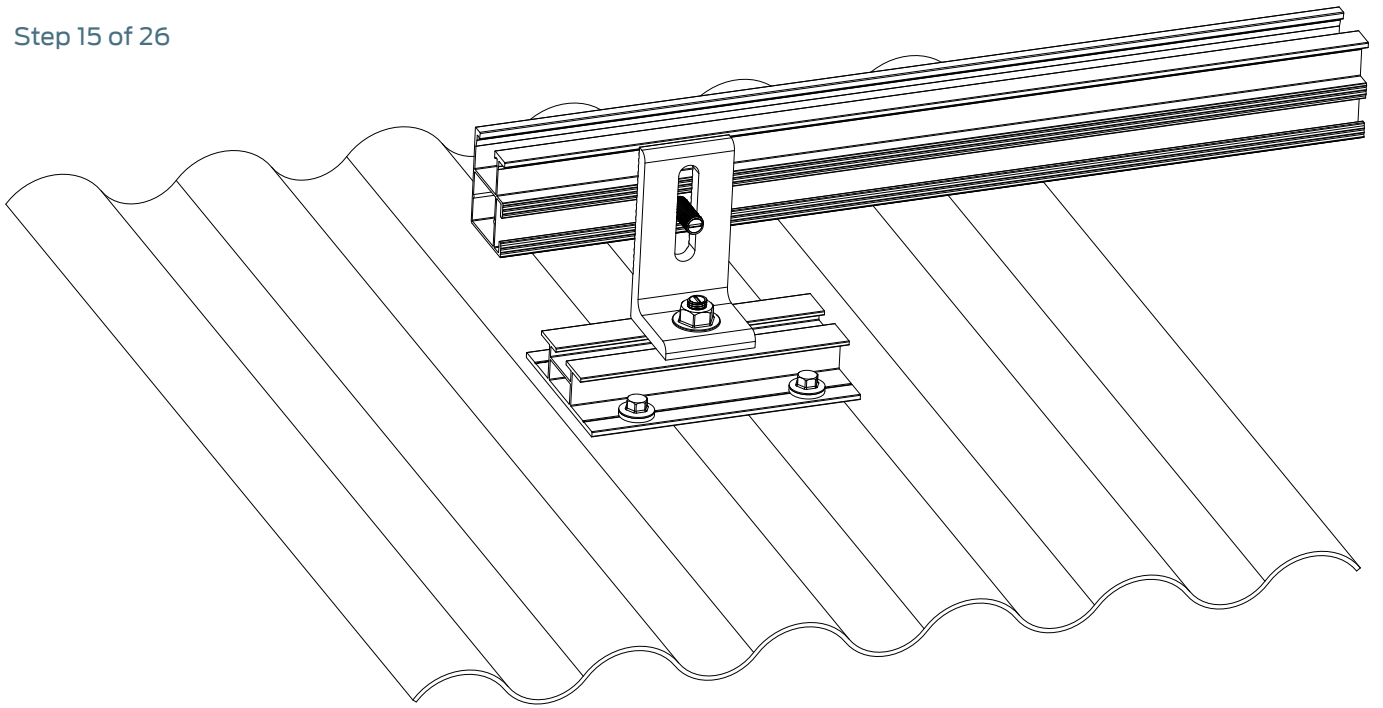

Step 16 of 26

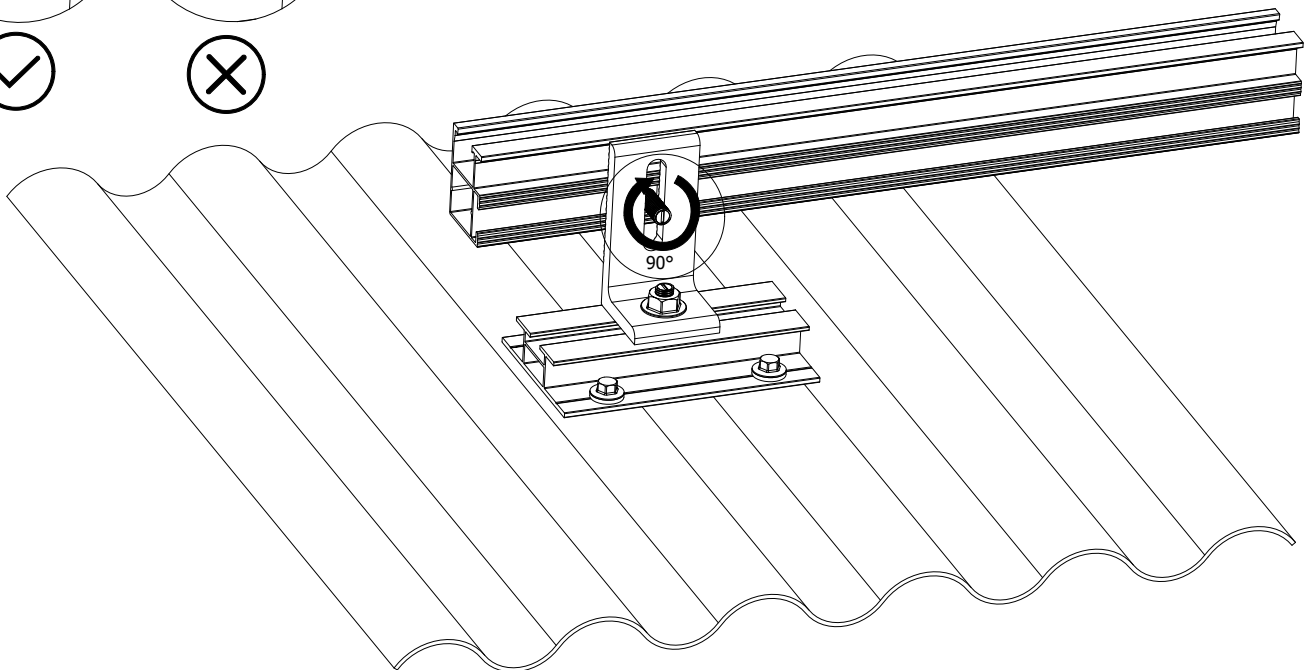
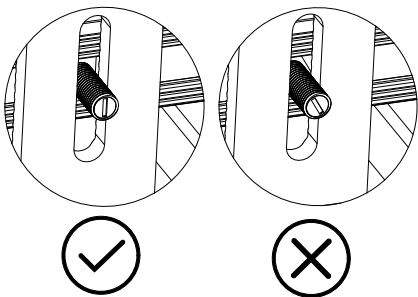

Installation Guide (continued)

Step 17 of 26

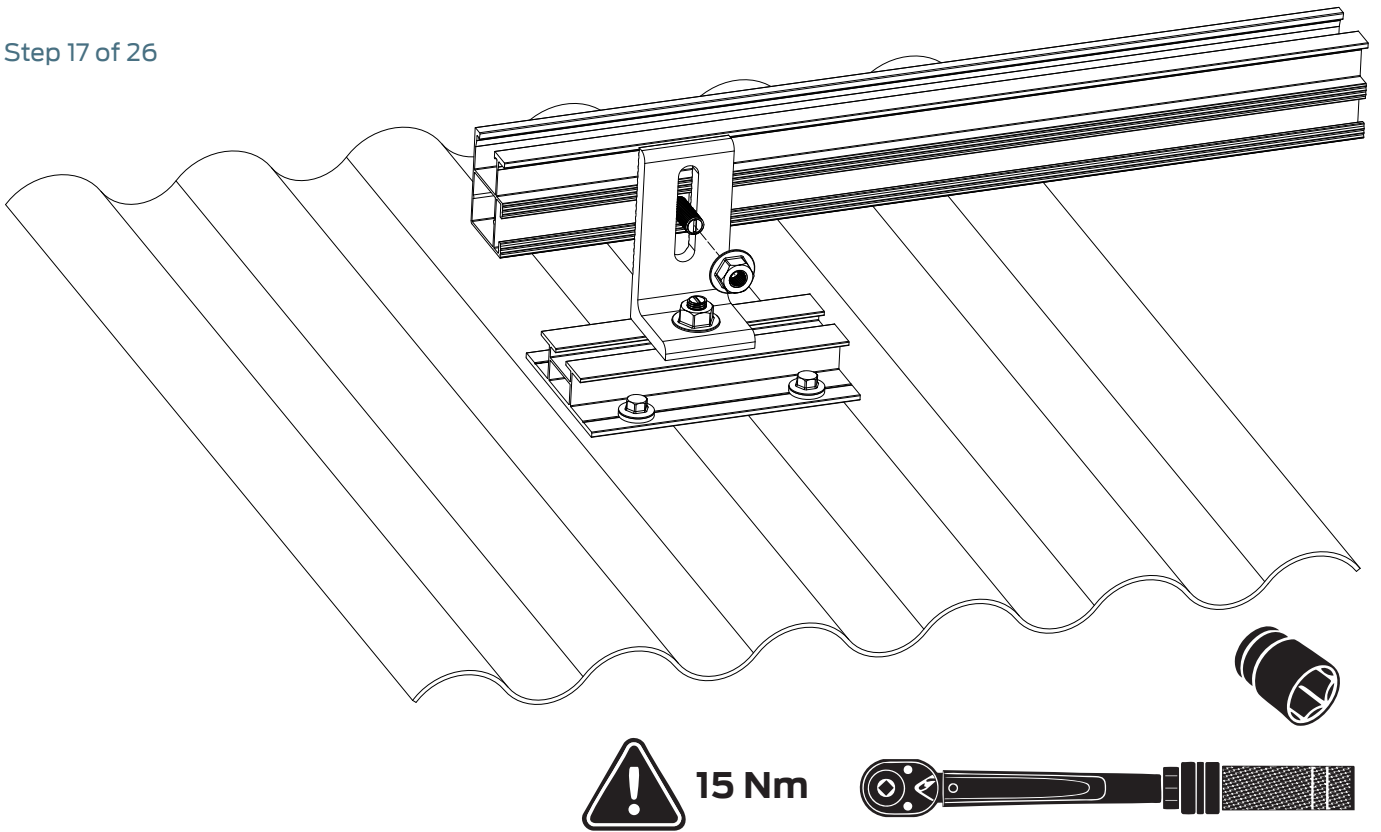

Step 18 of 26

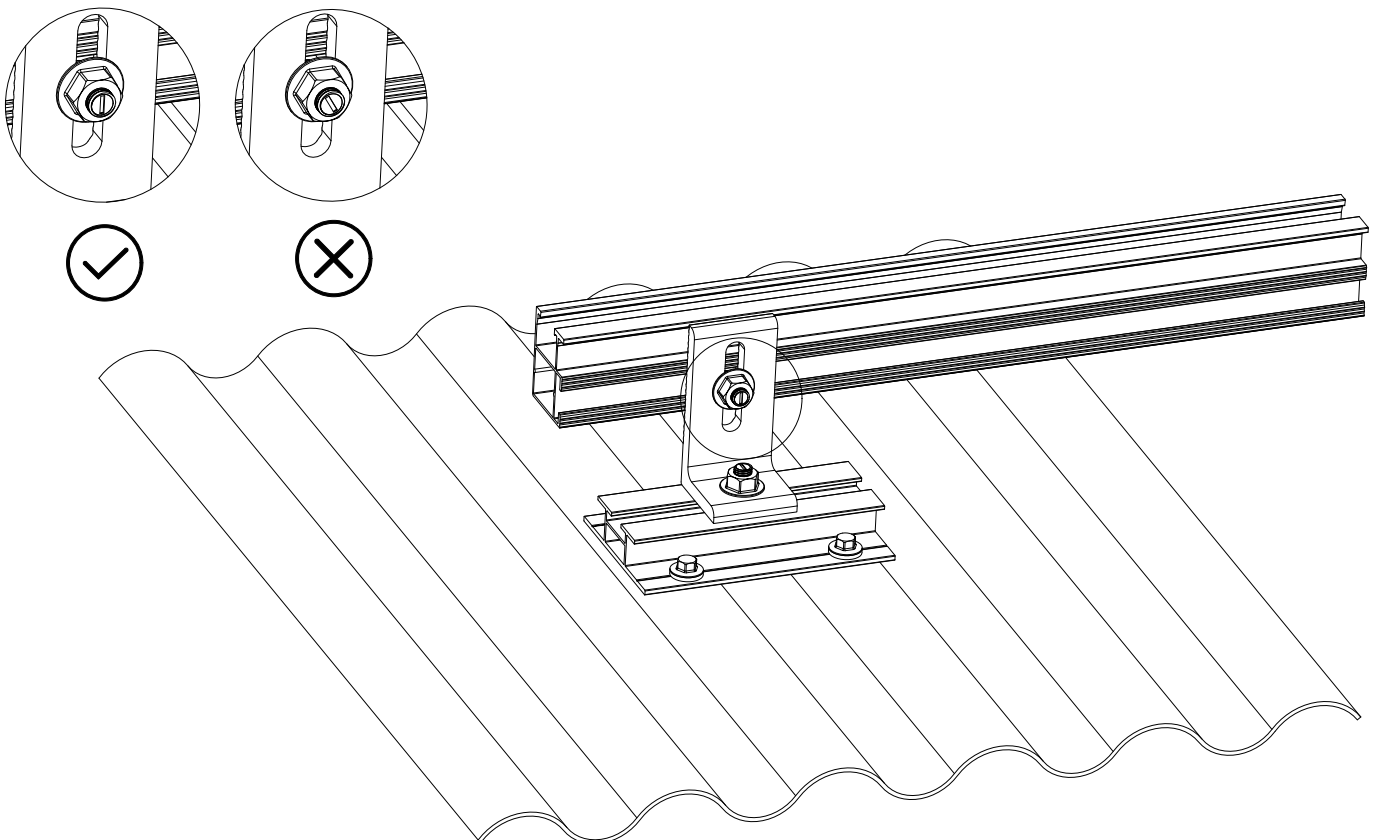

Installation Guide (continued)

Step 19 of 26

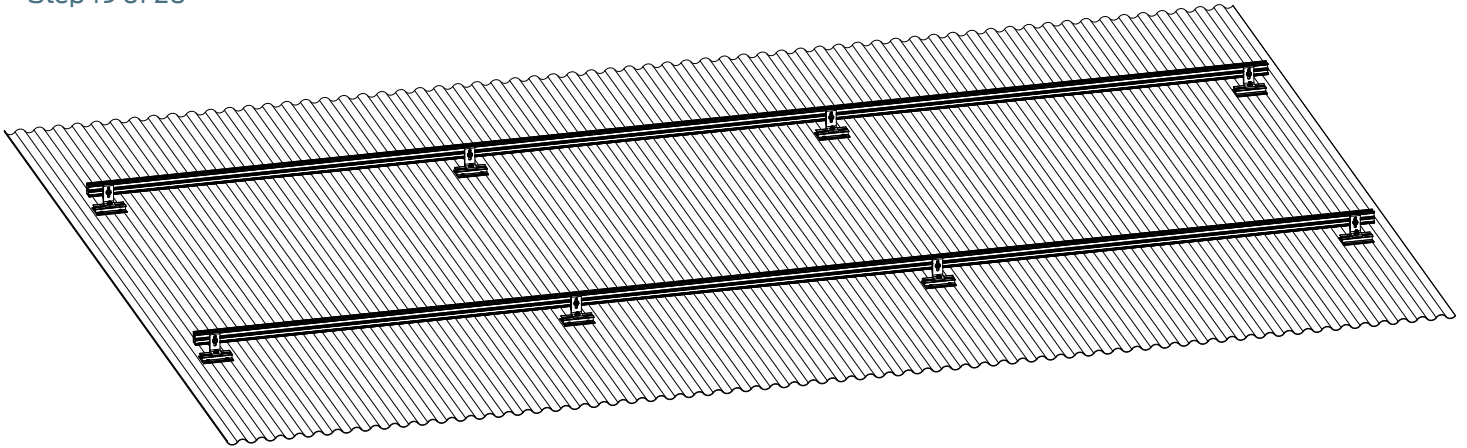

Step 20 of 26

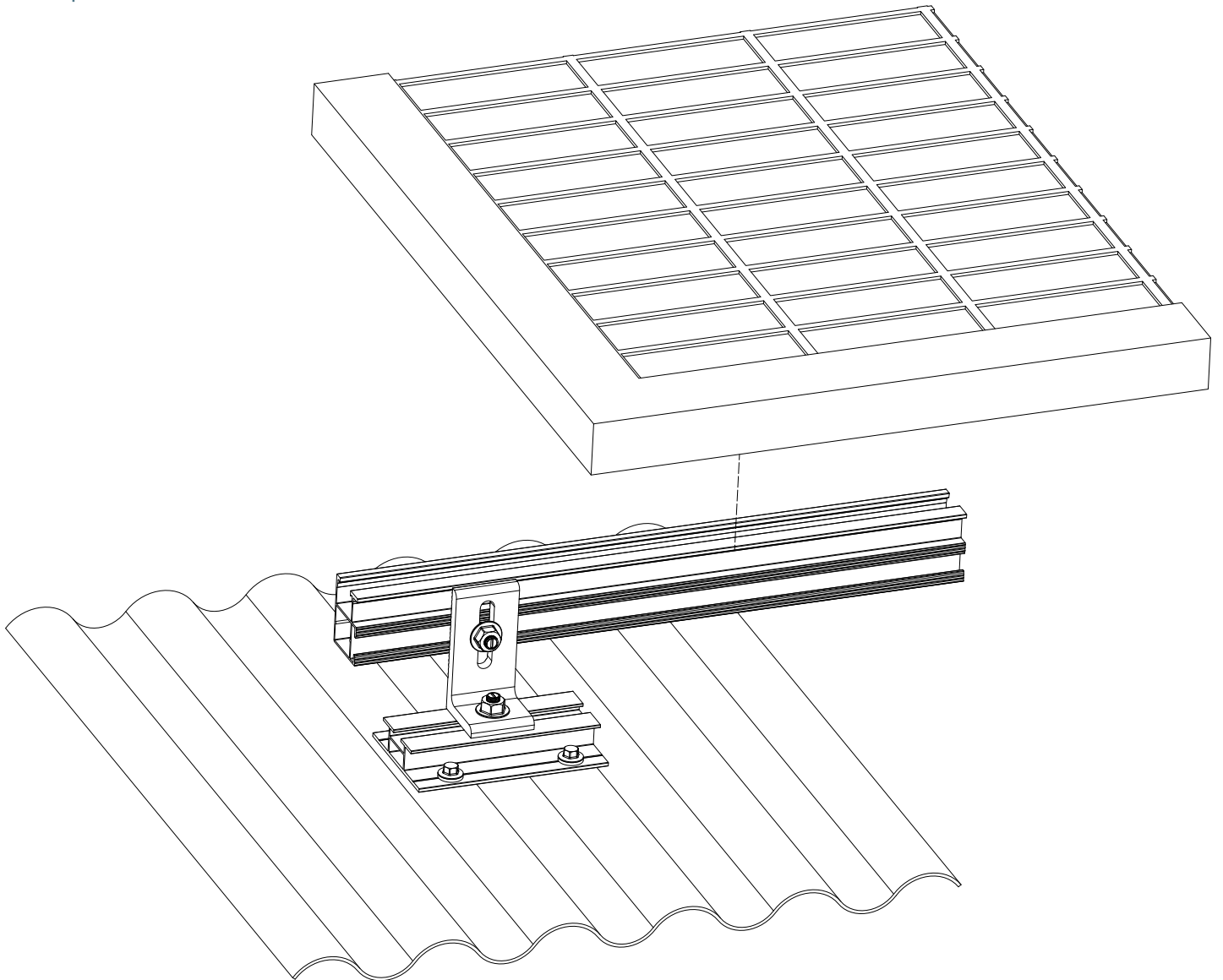

Installation Guide (continued)

Step 21 of 26

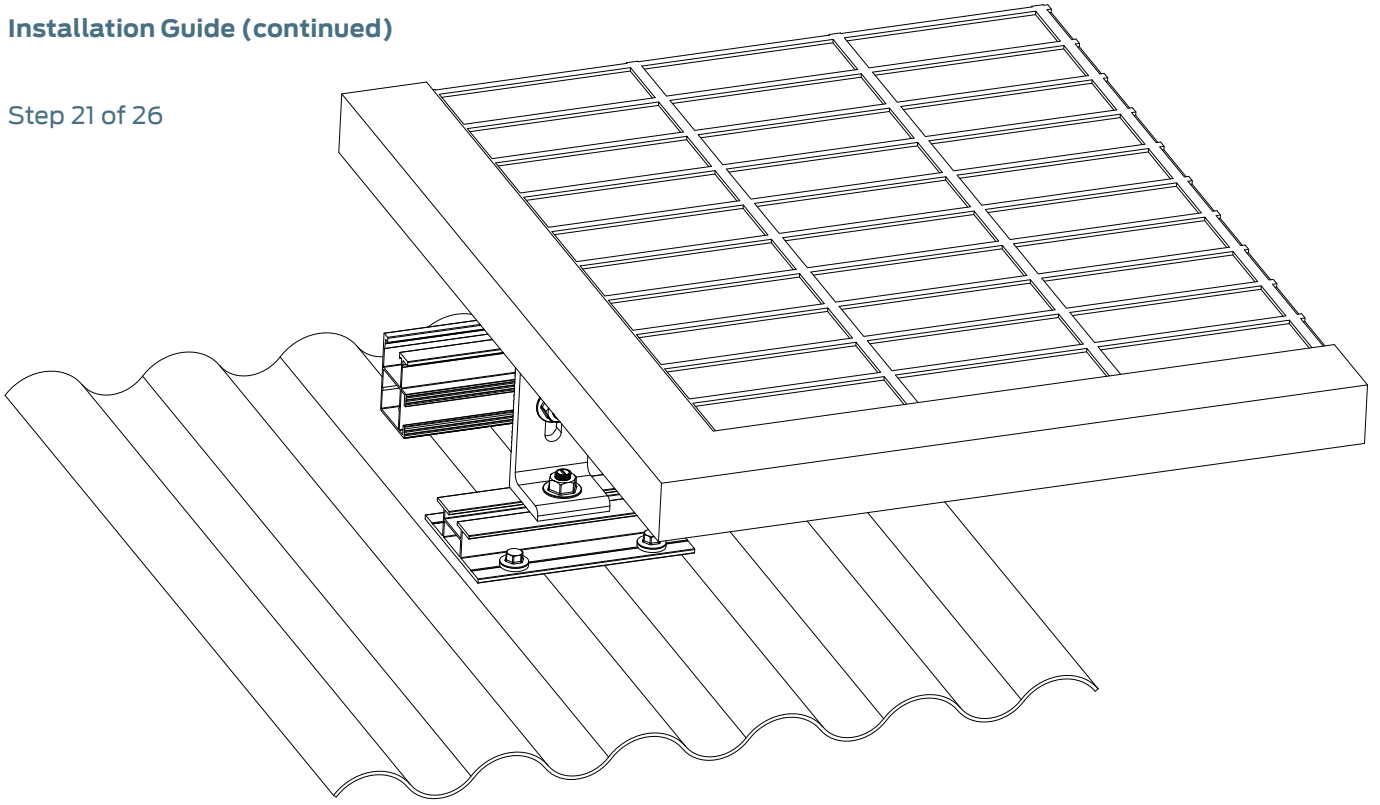

Step 22 of 26

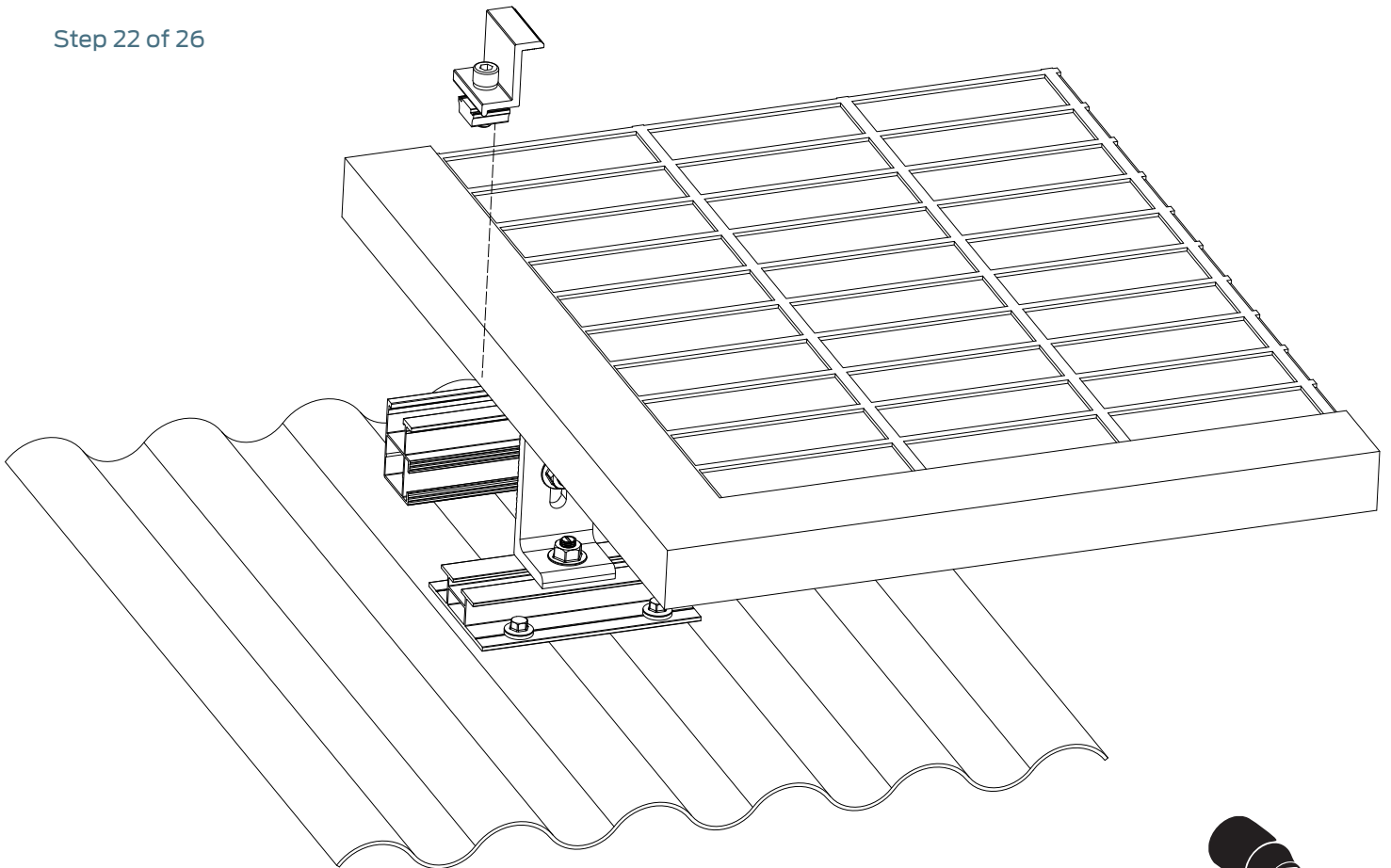

12 Nm



Installation Guide (continued)

Step 23 of 26

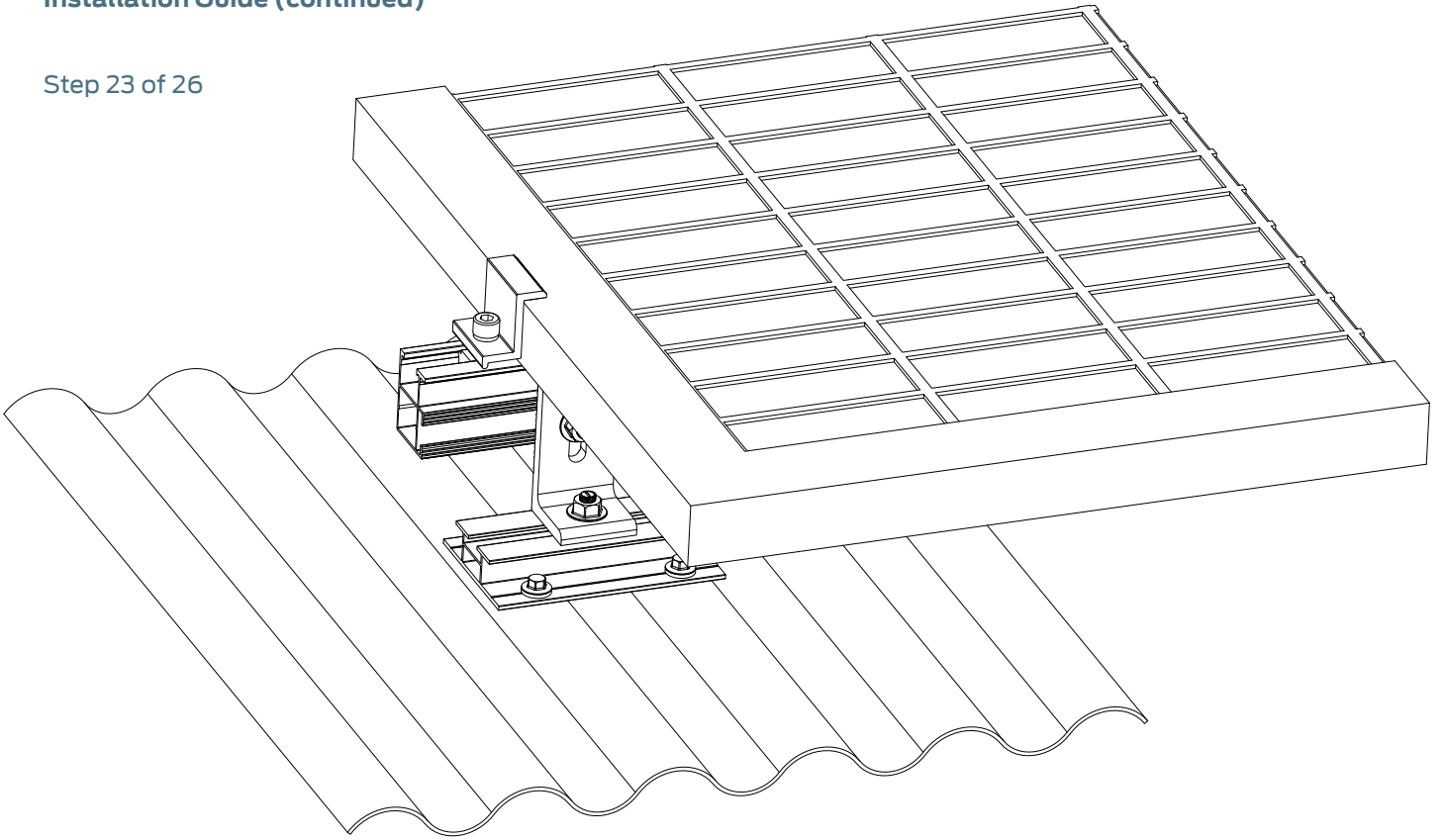

Step 24 of 26

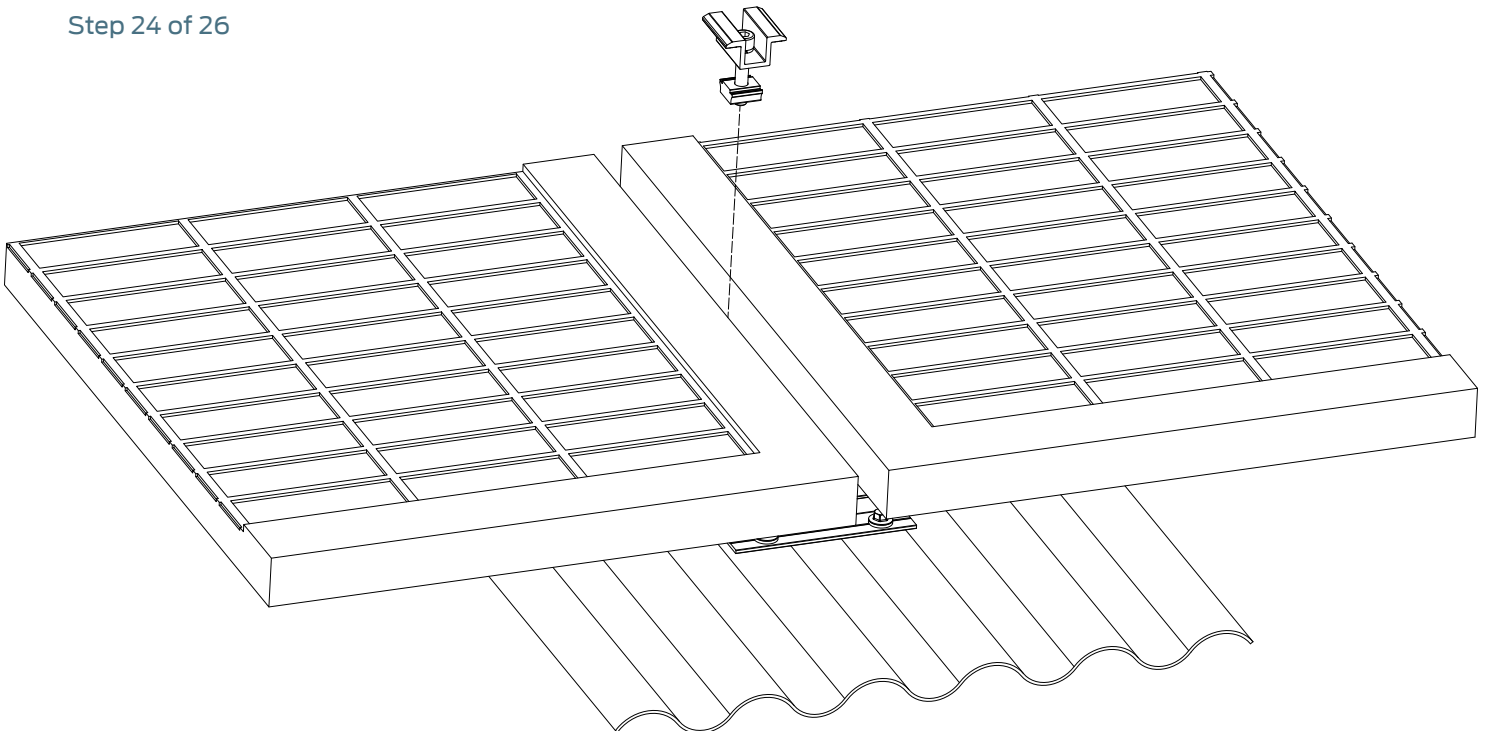

12 Nm



Installation Guide (continued)

Step 25 of 26

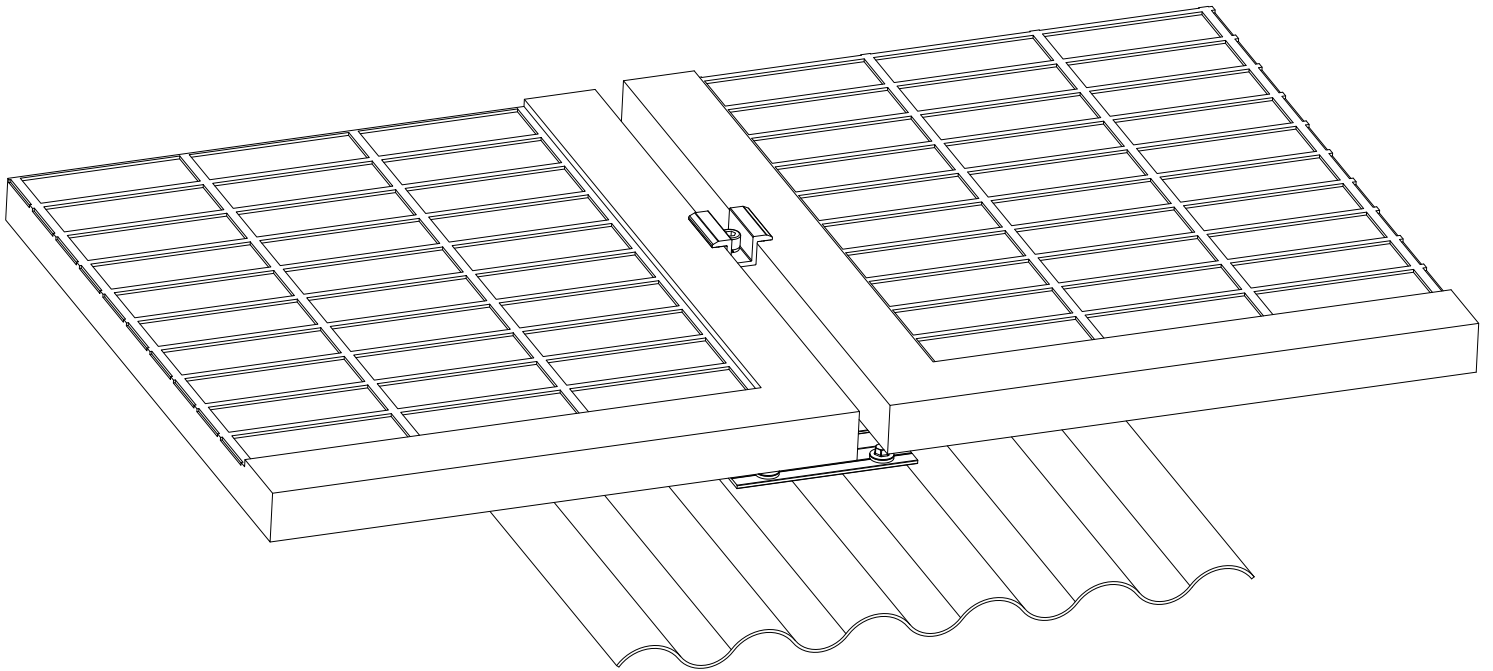

Step 26 of 26

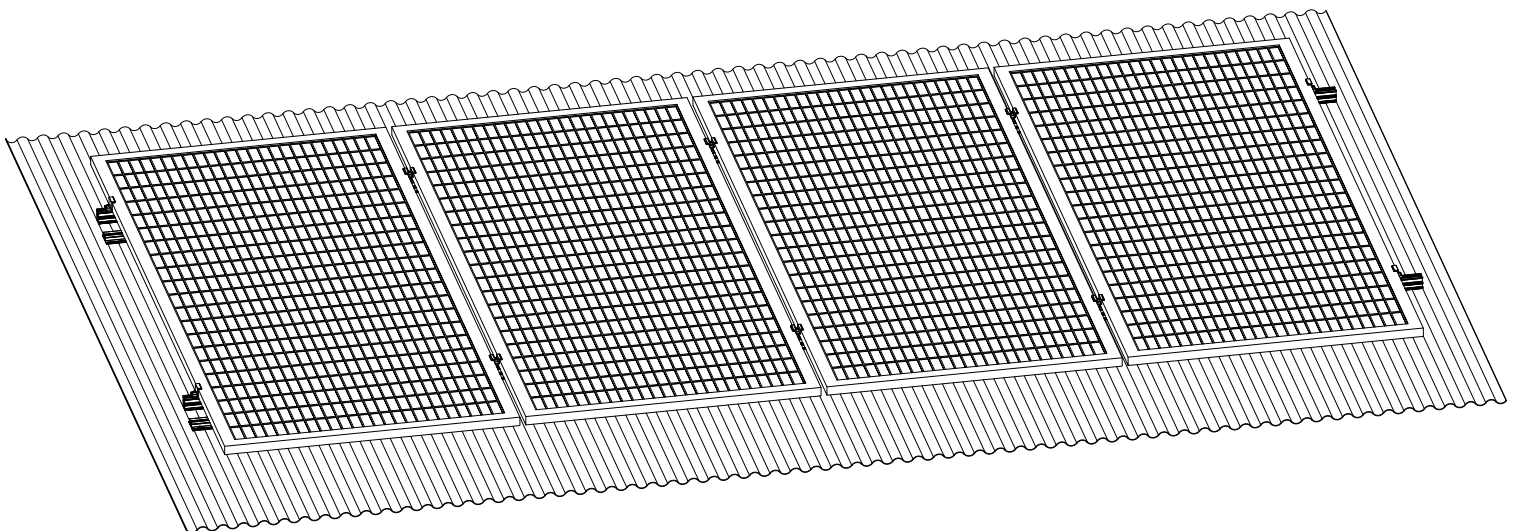

Rail Joiner Guide

Step 1 of 6

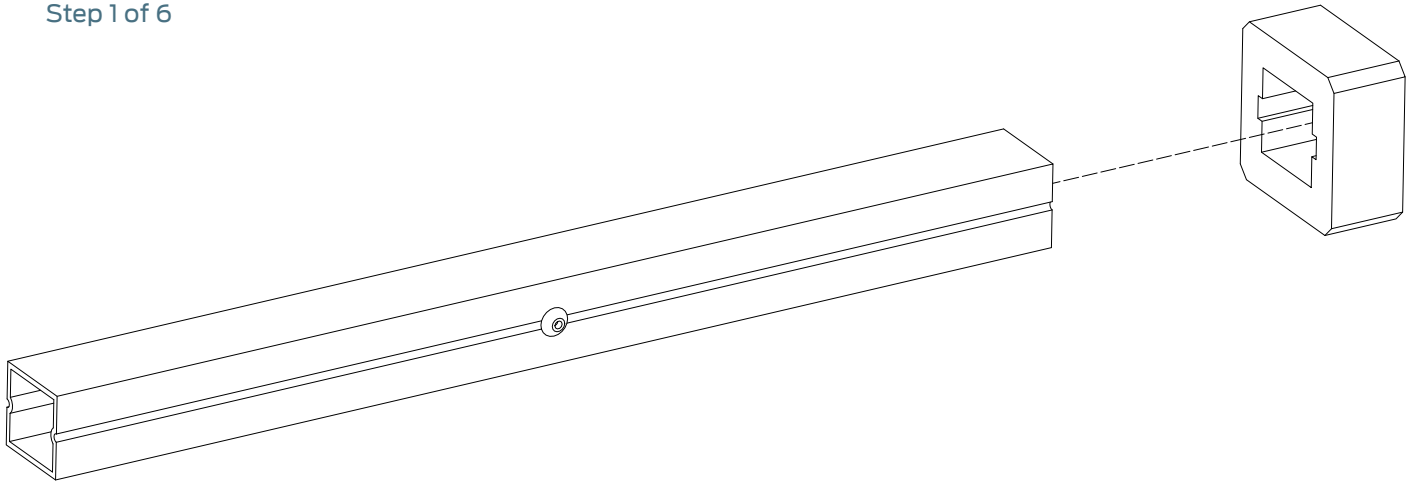

Step 2 of 6

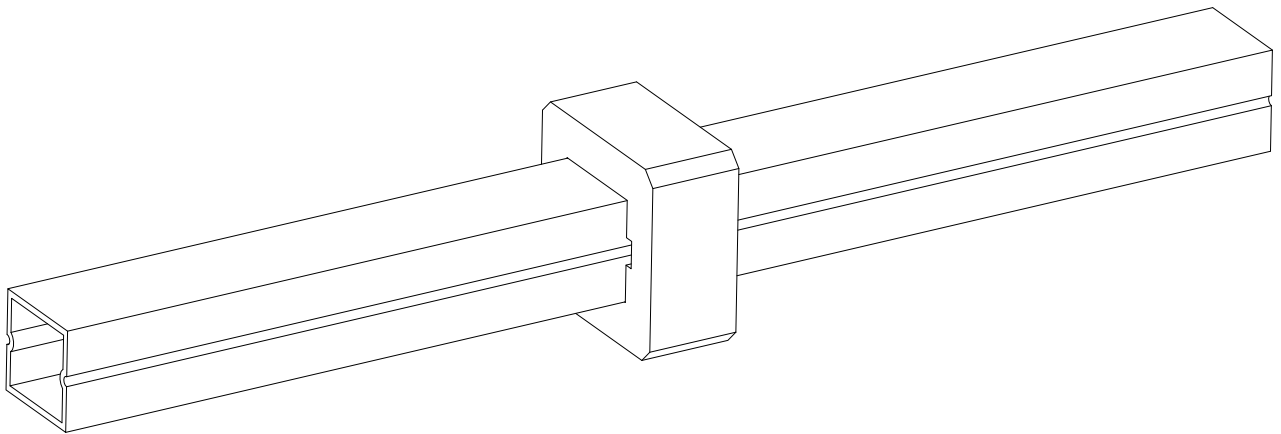

Step 3 of 6

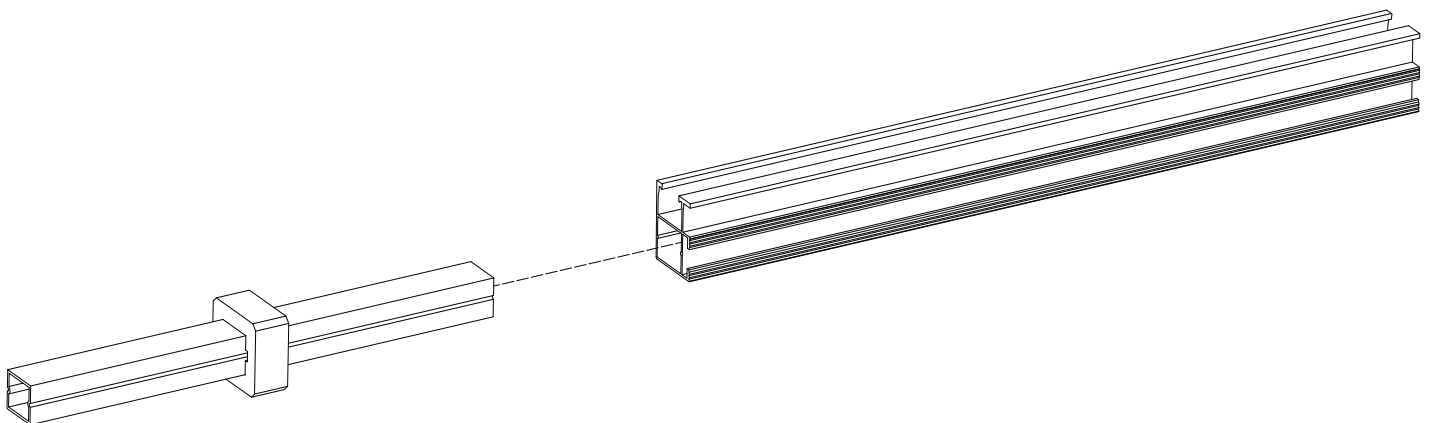

Railer Joiner Guide (continued)

Step 4 of 6

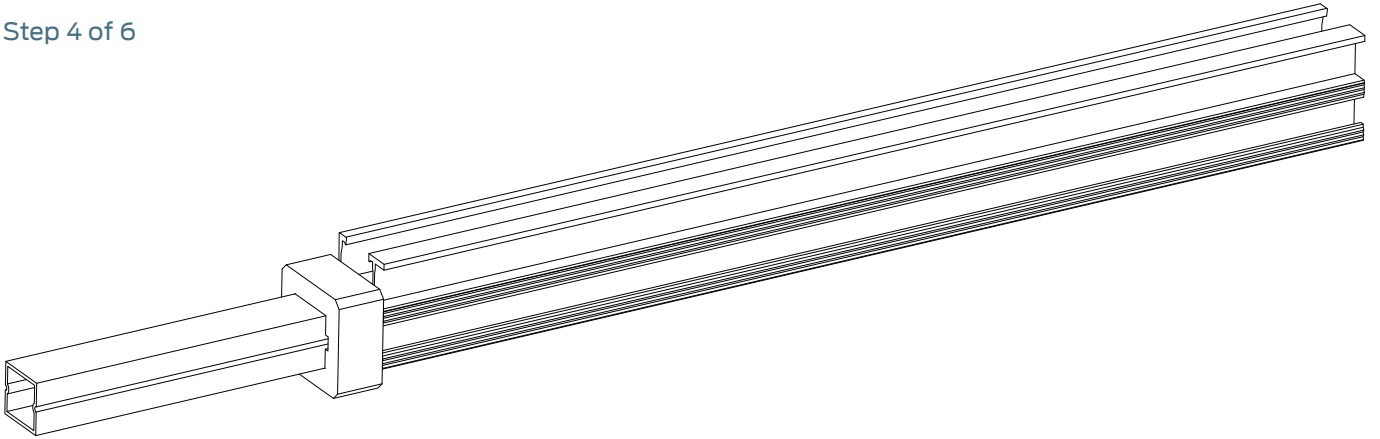

Step 5 of 6

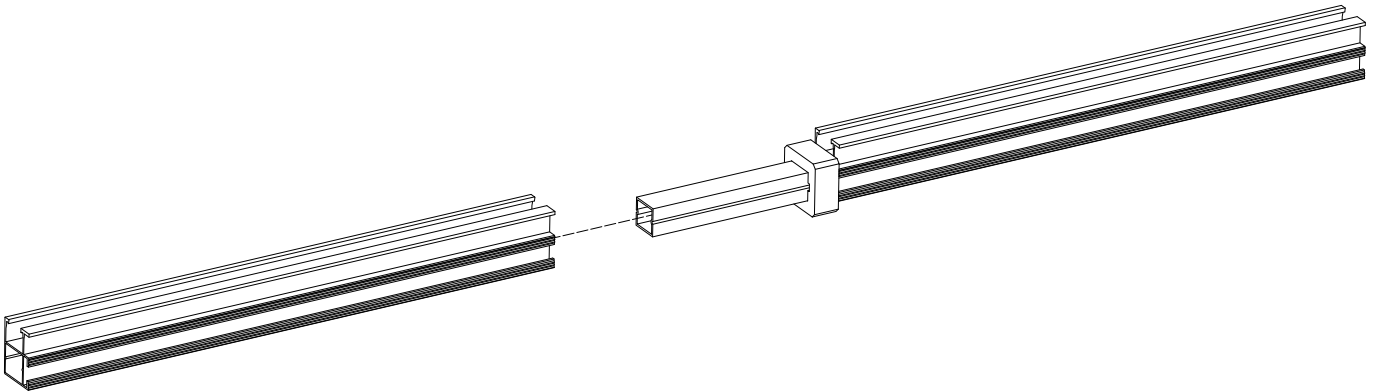

Step 6 of 6

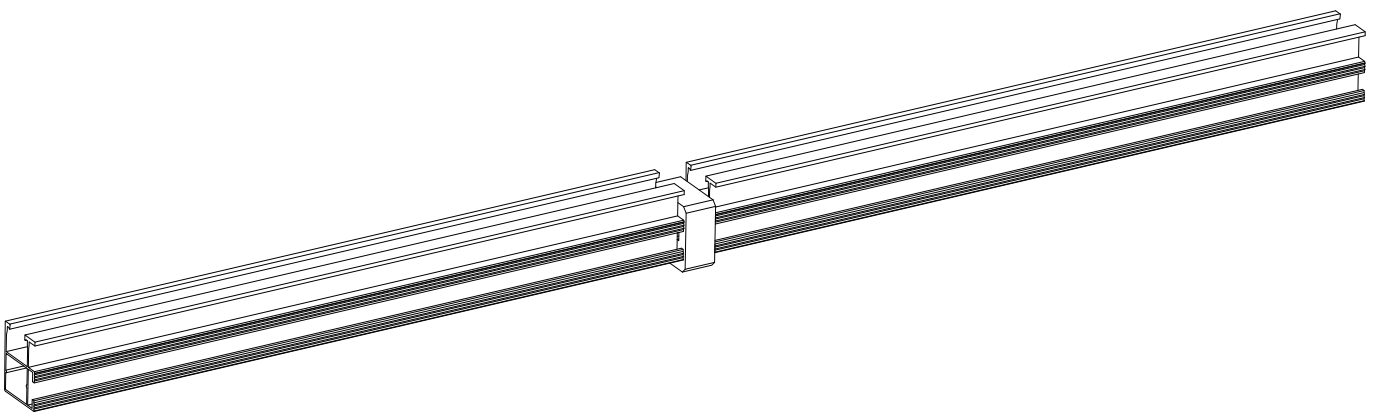

Post Installation

Warranty Registration

The customer must complete the warranty registration form, available on the SunFix website and/or provided upon request, within 30 (thirty) days of the delivery date. SunFix may, at its sole discretion, extend the registration period if the customer submits a written request before the expiry of the initial 30-day period.

The warranty is subject to the terms and conditions set out in the Sunfix (Pty) Ltd Limited Product Warranty.

Maintenance

The customer must ensure that the components are inspected and maintained for the duration of their service life in accordance with the Sunfix (Pty) Ltd Maintenance Manual which is available on the SunFix website and/or provided upon request.

Standard Terms of Trade

All transactions with Sunfix (Pty) Ltd are subject to our Standard Terms of Trade which is available on the SunFix website and/or provided upon request.



We are ready to secure your project!

Contact Us

 +27 31 207 1985  www.sunfix.co.za  info@sunfix.co.za

 Head Office: Unit 10, 1 Randworth Close, Red Hill, Durban